



ENDÜSTRİYEL TİP SALYANGOZ FANLAR (ALÇAK BASINÇ)



industrial type radial fans (low pressure)

GENEL AÇIKLAMA

Direkt akuple motorlu, DKP sacdan imal edilmiş, öne eğik kanatlı fanlardır.

Talep üzerine paslanmaz çelikten ve kayış tahrikli olarak imal edilebilir.
Kullanım Alanları: Fabrikalar, depolar, boyahaneler vb. az kirli hava sirkülasyonunda.

GENERAL DESCRIPTION

Directly coupled motor, made of DKP steel sheet, forward curved fans.

Other request stainless steel, belt driven and allows easier installation square body can be manufactured.
Used Areas: Factories, warehouses, dye-works etc.
less polluted air circulation available at.

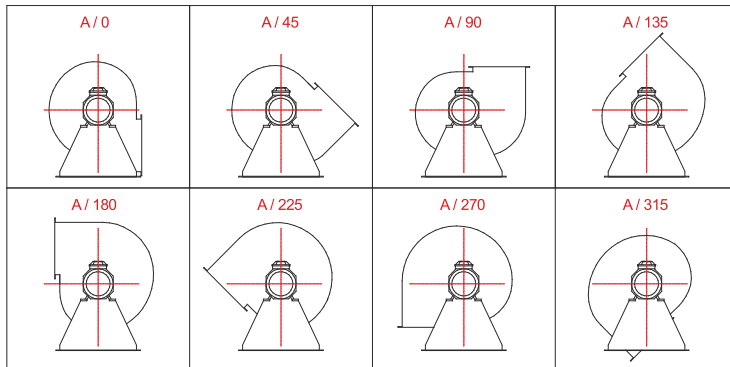

SOL YÖN A



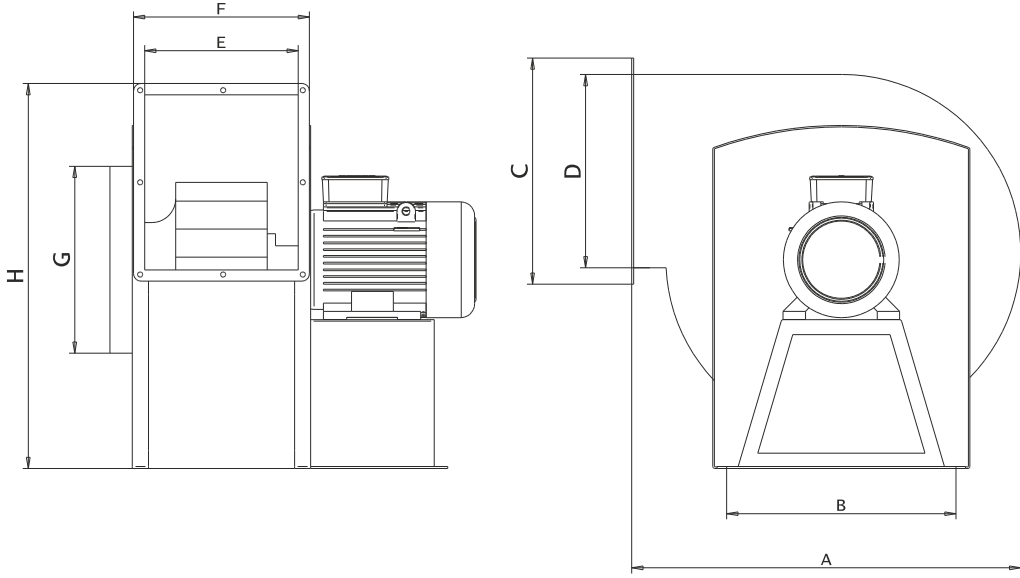

TEKNİK ÖLÇÜLER | TECHNICAL DIMENSIONS

Tüm ölçüler mm'dir. | All dimensions are in mm

Tip / Type	A	B	C	D	E	F	G	H
GABRF-2	510	360	310	260	180	235	200	580
GABRF-3	530	410	320	270	200	260	240	660
GABRF-4	600	410	340	290	220	270	260	690
GABRF-5	630	475	370	320	230	280	300	730
GABRF-6	630	475	370	320	250	300	320	730
GABRF-7	660	480	430	380	250	310	320	790
GABRF-8	780	600	490	440	280	335	330	870
GABRF-9	880	700	600	540	350	410	350	1050

TEKNİK VERİLER | TECHNICAL DATA

Tip / Type	GABRF-2	GABRF-3	GABRF-4	GABRF-5	GABRF-6	GABRF-7	GABRF-8	GABRF-9
Gerilim / Volt	380	380	380	380	380	380	380	380
Frekans / Hz	50	50	50	50	50	50	50	50
Güç / Kw	0,75	1,1	1,5	2,2	3	4	5,5	7,5
Debi m ³ /h	2500	3500	4700	6200	7000	8000	10000	12000
Devir / d-dak	1400	1400	1400	1400	1400	1400	1400	1400
Basınç / Pa	450	600	700	750	800	950	1200	1500

SAĞ YÖN B

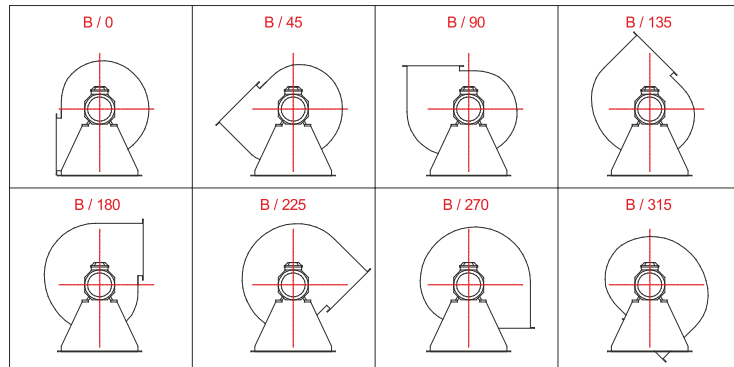

PERFORMANS VERİLERİ | PERFORMANCE DATA

GABRF-2

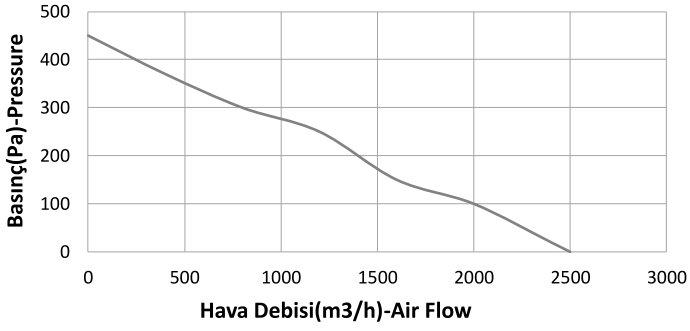

GABRF-3

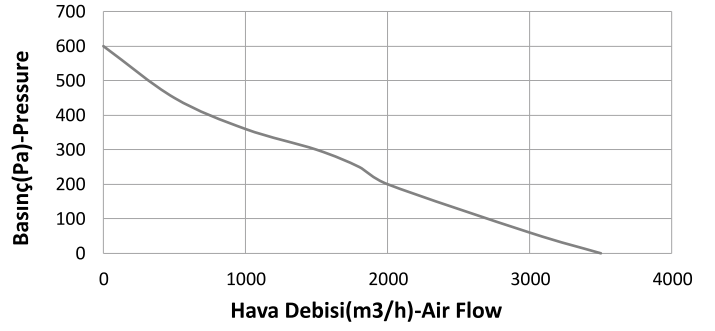

GABRF-4

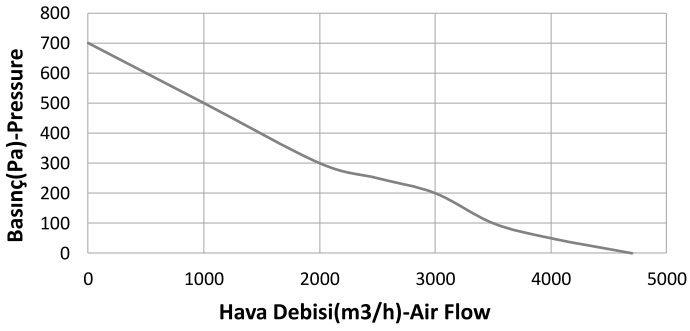

GABRF-5

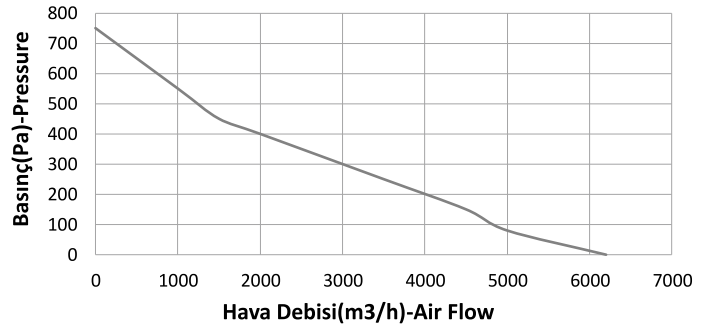

GABRF-6

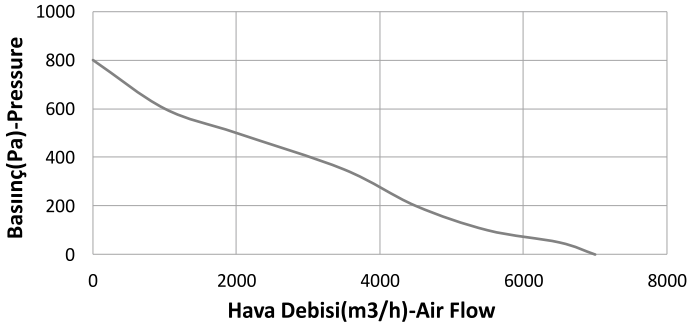

GABRF-7

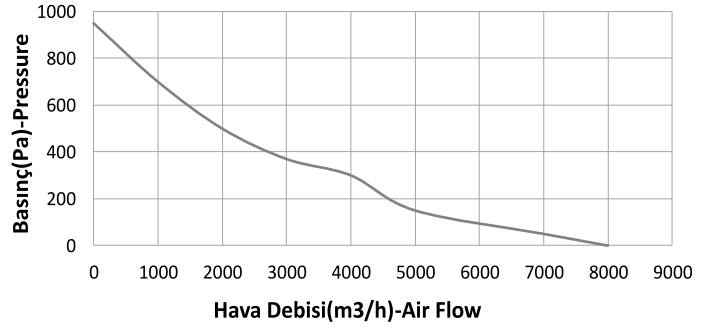

GABRF-8

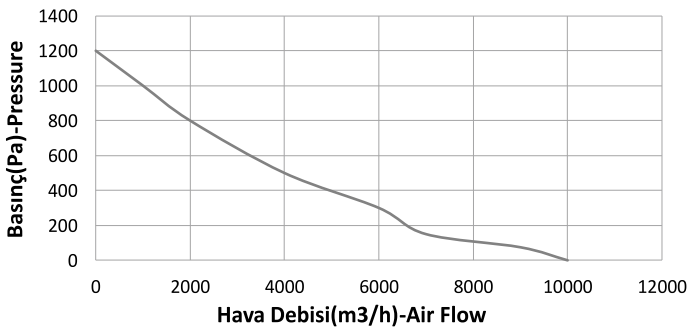

GABRF-9

